

OTL Resin Flooring Systems for Showering Areas

Bespoke Formers and Drain Options
for Resin Floors

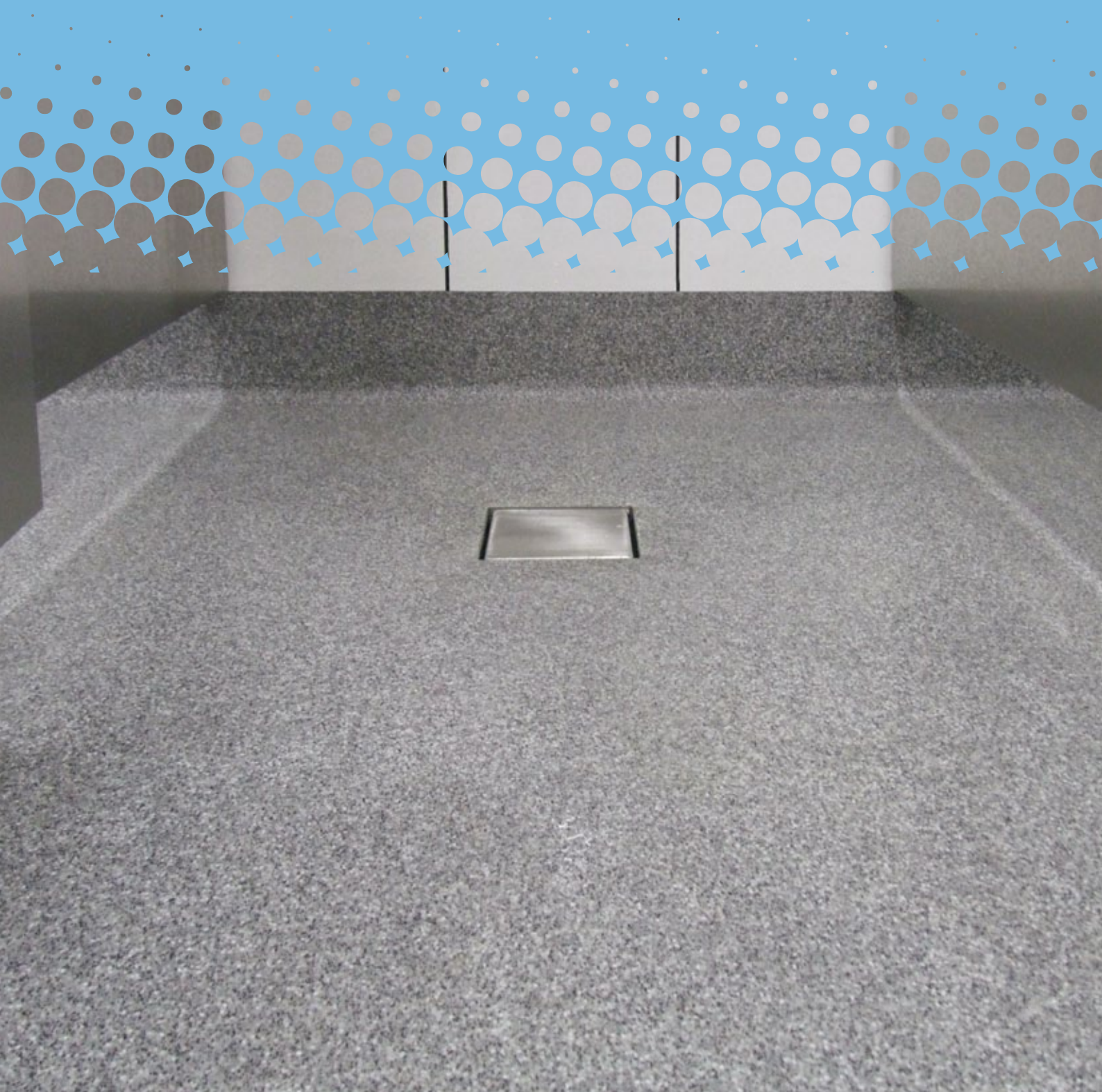

OTL Resin Floor Formers

On The Level made to measure birch plywood formers for resin floors are ideal for wet areas where a seamless resin floor finish is required. As with all our other bespoke formers, the size and position of the waste outlet are manufactured to suit the client's requirements.

On The Level birch plywood formers for resin floors are suitable for installation onto most rigid subfloors; including concrete slabs / block and beam / concrete plank flooring/suitable timber supported floors etc. All On The Level Birch plywood formers for resin floors are supplied with a full waste support (the waste support is the same size as the former to ensure complete support to the former).

OTL Resin Floor Components

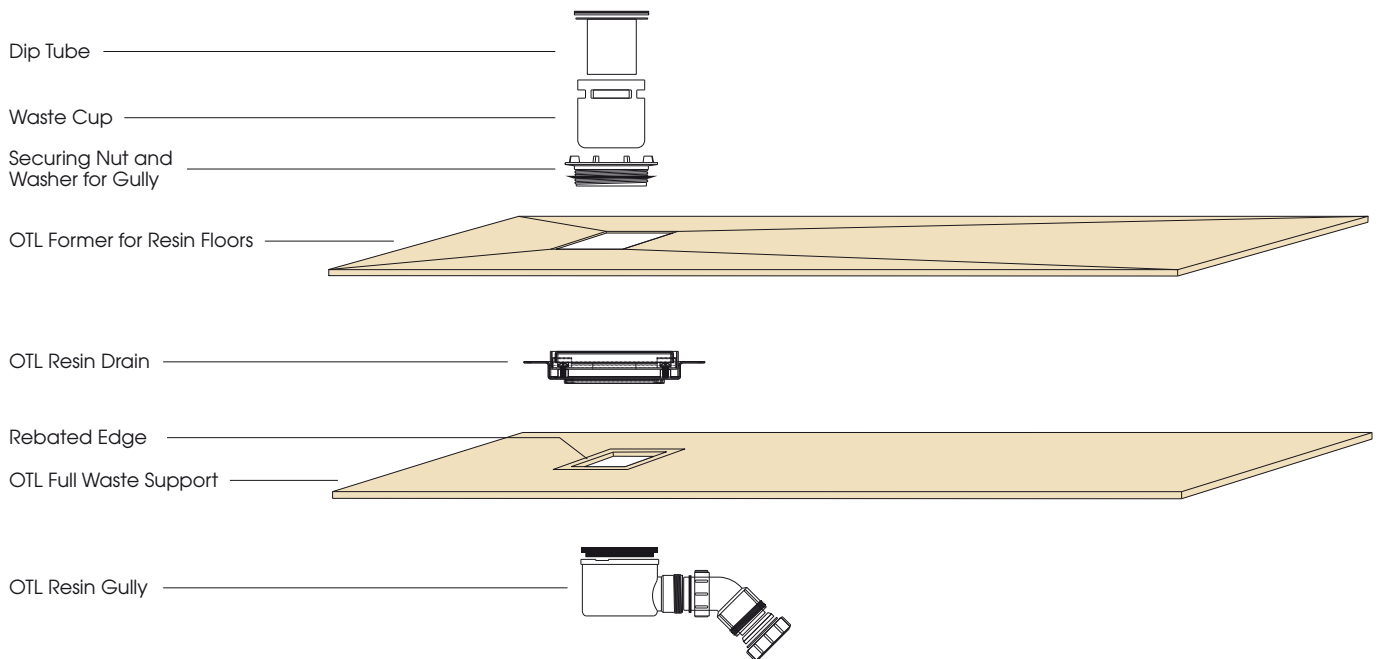

A resin floor is a tough chemical resistant floor finish which is stronger than concrete. It is produced by a chemical interaction between two polymers. The resin system forms a seamless, impervious and easily cleaned floor surface that will not harbour bacteria. Inert properties mean that it does not taint, can be steam cleaned (heavy duty) and is resistant to cleaning chemicals. Ease of cleaning and longevity of resin systems can substantially reduce maintenance costs.

Resintek quartz flooring systems offer the benefit that they can be laid to follow falls and coved to form skirting detail. However, these screed systems offer the added benefit that they are highly decorative. These systems can range in thickness from 4mm to 6mm depending on the environment and whether a medium or heavy-duty system is required.

With a modified quartz system and the application of a decorative quartz scatter, it is possible to provide a highly decorative slip resistance system at 4.5mm. Environments that suit this system include kitchens, showers and swimming pool surrounds.

With highly skilled workmanship it is possible to apply Resintek screed (plain and decorative) to walls. By the application of resin to both floor and wall these systems provide a fully enclosed system with excellent hygienic qualities. Showers and changing rooms offer the ideal environments, especially with the use of decorative quartz screed and scatter for slip resistance.

For technical information about resin floors contact: technical support/sales at sales@resintekservices.co.uk

OTL Tile Sets and Water Trap



OTL REF: OTL RFPT-B
(brushed finish)



OTL REF: OTL RFPT-P
(polished finish)



OTL REF: OTL RFPT-L
(brushed finish)



OTL REF: OTL RFPT-M
(brushed finish)



OTL REF: OTL RFPT-S
(brushed finish)



OTL REF: OTL RFPT-T
(brushed finish)

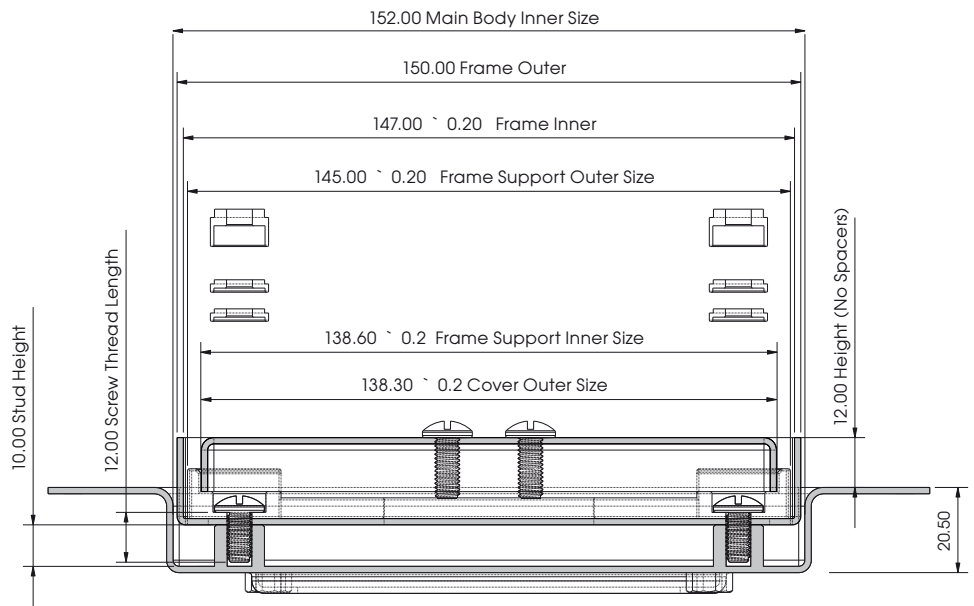

OTL REF: OTL ST90-HPB
50mm Water Seal Trap Body
with 2" Multifit Outlet.
Overall height with Tile 120mm.
Flow rate 50 l/min.
(Flow rate calculated under a
constant 15mm head of water)

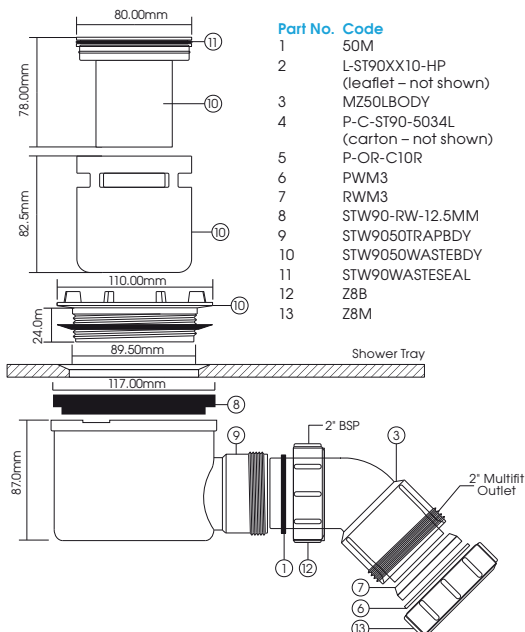

All Tile Sets are
manufactured from
Grade 304 Stainless Steel

Section through Block and Beam Floors

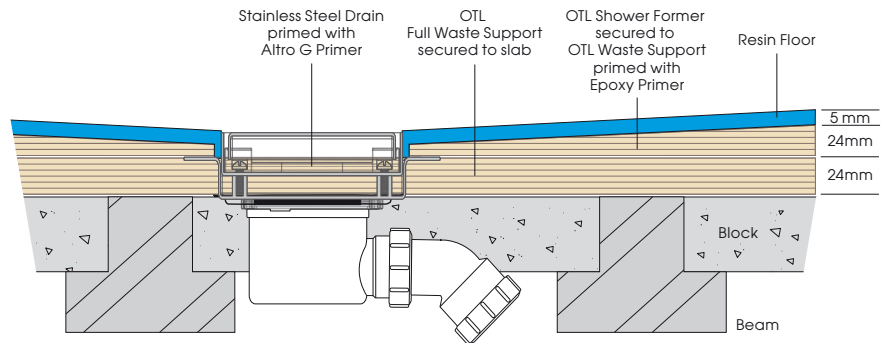

Section through Concrete Slab

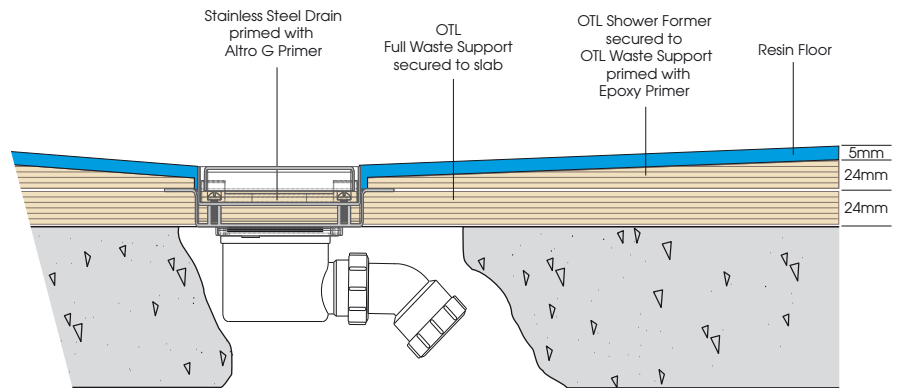

Environmentally conscious On The Level only use birch plywood sourced from Finland, Estonia and Russia. Manufactured in the UK and backed by a PEFC comprehensive certification making in an extremely environmentally responsible product.

With an excellent strength to weight ratio our OTL Concealed Formers are manufactured from one of the most dimensionally stable plywoods. The pre-manufactured wood is beautifully smooth, has a hard surface and distinctive pale sheen.

All 17 laminations are bonded with a phenolic resin giving a traditional toughness and all formers, once installed, using our Waste Support System can cope with an applied pressure of 6.7kN (approx 105.5 stone). See our BSI report on our website.



On The Level

Unit 8 Youngs Industrial Estate, Stanbridge Road,
Leighton Buzzard, Bedfordshire LU7 4QB

Tel: 01525 373202 **Fax:** 01525 373222 **Email:** sales@onthelevel.co.uk

Web: www.onthelevel.co.uk

